



County Engineer

Mike Kendell, P.E.

VOTER SHEET INFORMATION

Bear Hollow Drive Traffic Calming

Summit County has been working in cooperation with Sun Peak HOA and a volunteer Traffic Calming Committee to reduce speeds along Bear Hollow Drive. The intent is to reduce speeds to provide a safer and more pleasant neighborhood. In accordance with the Summit County Traffic Calming Program, included with this letter is a card for your vote on accepting or rejecting the plan as illustrated on the back. On the back of this letter Figure 1 shows the proposed locations of the traffic calming devices, Figure 2 is a picture of what it should resemble (taken from Trailside Drive), and Figure 3 show the detailed drawing of the traffic calming devices. Other traffic calming devices like speed humps were looked at for this area but because of the slope of the road and because PCFD will not allow them on this road, speed humps cannot be considered. Return the card via mail (stamp required) or drop it off at the Engineering Department at 60 N Main St in Coalville. **Return on or before Monday March 5th 2021.**

Proposed: There have been delineator post up in two different locations along Bear Hollow Drive last summer where the installations of center islands are proposed. Going west on Bear Hollow Drive the 1st location is after Picabo Street, the 2nd location is close to the Dubois Trail crossing, and the 3rd is past Mahre Drive (location shown on back). The center island will consist of a 13-foot-wide island in the middle of the road with 11-foot lanes to travel around it. There will be a 4-foot asphalt shoulder provided on the outsides of each area so bikes and pedestrians will not have to travel through the center island. The center island will be filled with 4 to 6 inch rock with warning signs on each end of the island.

Funding: Summit County has already approved the funding for this project and if accepted, the Summit County Engineering Department will oversee the construction of the project and it will be completed in the summer of 2021.

Additional information is available by contacting:
Brandon Brady, P.E. Summit County Engineering Department
(435)336-3294 or bbrady@summitcounty.org



Figure 1: Proposed Traffic Calming Locations



Figure 2: Example of Center Island on Trailside Drive

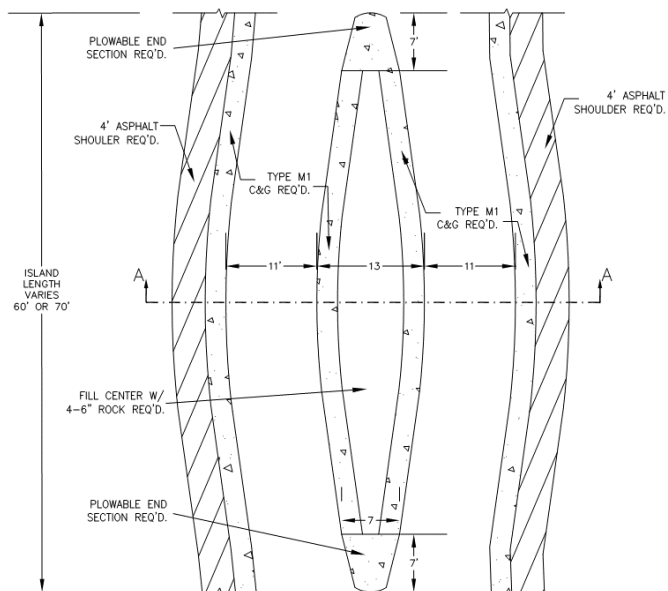

Figure 3: Detail Drawing of Center Island

60 North Main, P.O.Box 128, Coalville, UT 84017
 Coalville (435) 336-3250 · Kamas (435) 783-4351 ext. 3250 · Park City (435) 615-3250
 Fax (435) 336-3043